

QUALITEST
ADVANCED TESTING TECHNOLOGIES

QUALITEST™

Crawler-Type Self-Propelled Multifunctional Soil Investigation Machine - QualiSPT™ LC



APPLICATIONS

Crawler-Type Self-Propelled Multifunctional Soil Investigation Machine - QualiSPT™ LC

QualiSPT™ LC is a crawler-type, self-propelled, multifunctional soil investigation machine. Designed for versatility, it performs rotary/auger operations on a single drilling rig and conducts standard penetration tests (SPT). Lightweight, efficient, and budget-friendly, it delivers fast, economical performance making it the perfect choice for environmental soil sampling.



Applications

- Standard penetration test-SPT.
- Soil sampling with percussive core barrels.
- Rotary drilling, auger drilling.

FEATURES

Crawler-Type Self-Propelled Multifunctional Soil Investigation Machine - QualiSPT™ LC Features

- **Compact & Portable:** Easily transported using standard vans.
- **Stable & Adaptable:** Rubber tracks and a four-leg leveling system ensure secure positioning on-site.
- **Adjustable Speed:** Rotary head operates at four selectable speed settings.
- **Dual-Function System:** Combines a drop weight mechanism with rotary drilling in one unit.
- **Hydraulic Winch:** Enhances maneuverability and operational efficiency.
- **Streamlined Design:** Highly integrated industrial build for durability and space efficiency.
- **Quick Conversion:** Effortlessly switch between drilling, sampling, and testing functions.

TECHNICAL SPECIFICATIONS

Crawler-Type Self-Propelled Multifunctional Soil Investigation Machine - QualiSPT™ LC Technical Specifications

Crawlers	
Crawler Chassis Width (retractable)	790mm (min) - 1080mm (max)
Crawler Chassis Length	1200mm
Rubber Crawler Width	230mm

Max. Gradeability	27%
Power Pack	
Engine	Yunnei YN25
Rated Speed	2400 rpm
Power	37 kW
Fuel Tank Capacity	45 L
Hydraulic Oil Tank Capacity	120 L
Rotary Head	
Max. Torque	220 daNm
Max. Speed	900 rpm
Stroke	1800 mm
Pull-Up	2500 daN
Pull-Down	2500 daN
SPT System	
Drop Height	760 mm
Drop Weight	63.5 kg
Mast	
Winch Lifting Force	500 daN

Clamp	Clamping Diameter Range	30-180 mm
	Clamping Force	6000 daN
	Break-Out Torque	332 daNm
Mud Pump		60 L/min, 80 bar
Total Weight		2500 kg

Accessories

- SPT probe rod dia.42mm×1m×11 pcs
- SPT split sampler 1 pc
- SPT probe hoist plug 1 pc
- Wireline coring bit BQ NQ HQ (length 1.5m, optional)
- Core barrel (optional)
- Auger (optional)
- Other drilling tools can be configured as required.
- Walking system remote control (optional).



Drawing and Details

2398

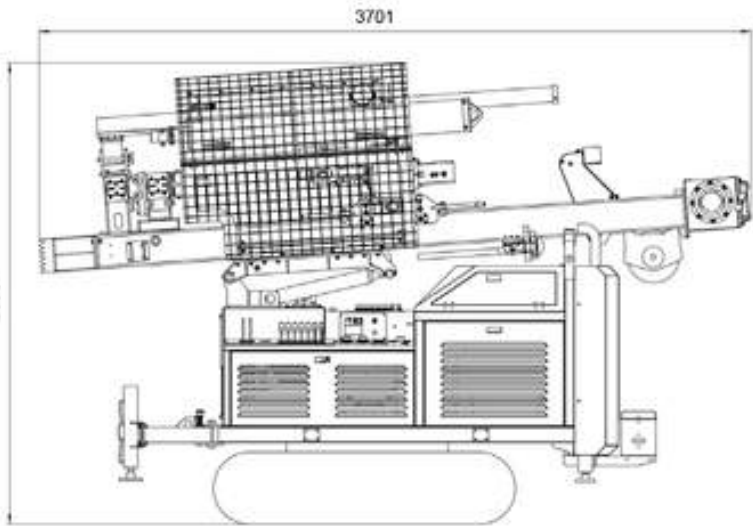

2013

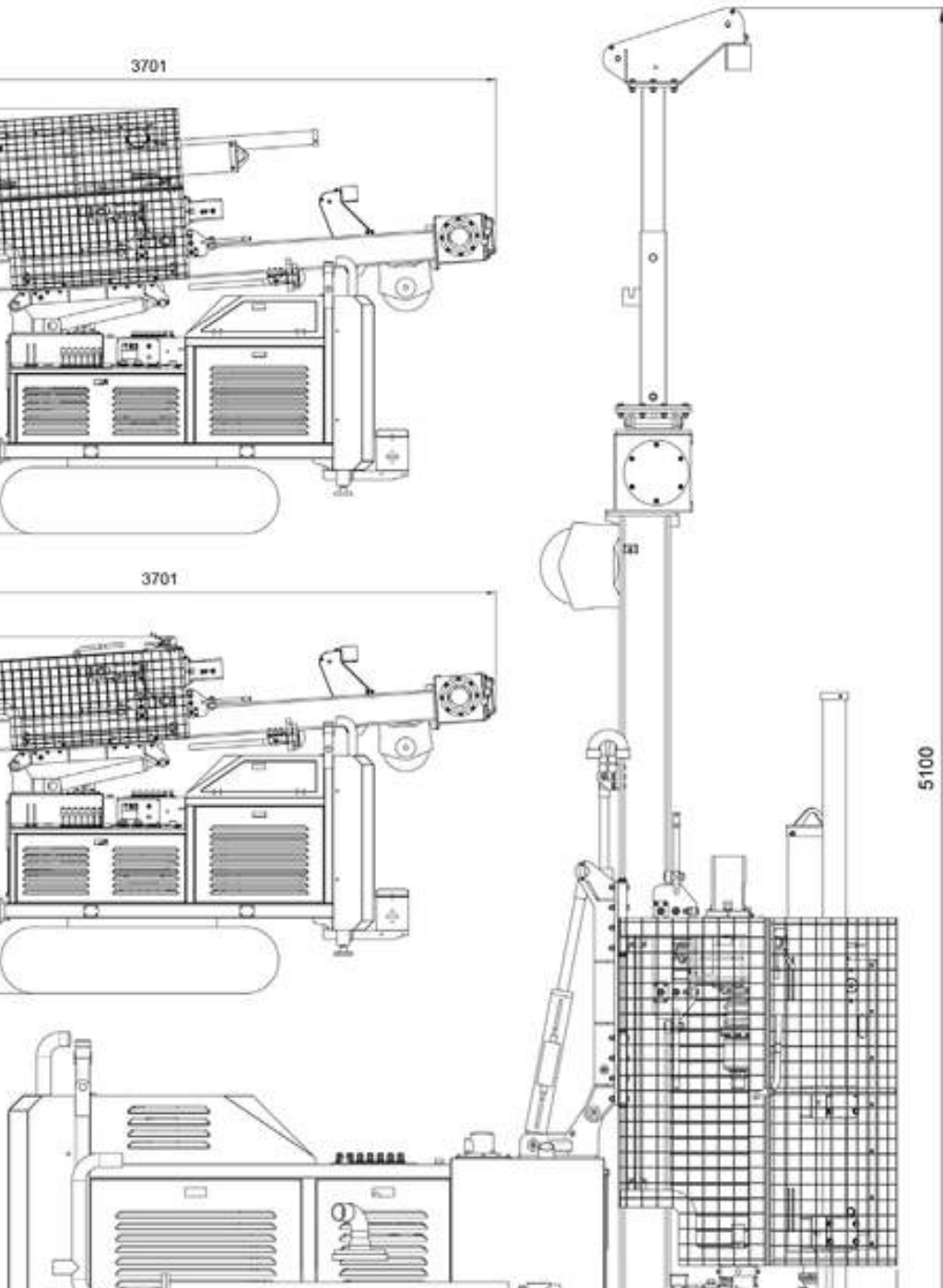
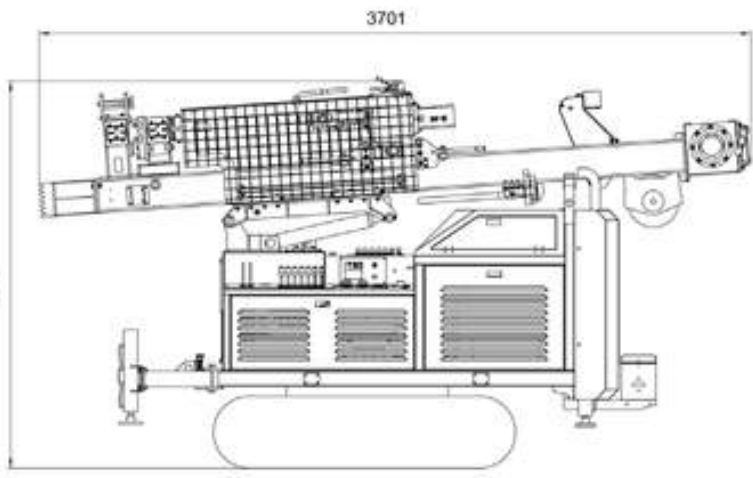



ADVANCED TESTING TECHNOLOGIES

USA | CANADA | UAE | GCC | EU | INDIA | APAC | AFRICA | LATIN AMERICA

Connect with us

Contact our **QualiTeam** today to find out how we can help your organization **select the most suitable testing solution** for your application, requirements, and budget.

Qualitest USA (Corporate Sales Office)

Toll-Free: 1.877.884.TEST (8378) | Fax: 954.697.8211
E-mail: info@qualitest-inc.com
Address: 8201 Peters Rd., #1000,
Plantation, FL 33324, USA.

Qualitest Canada & International

Tel: +1.905.944.9825 | Fax: +1.905.944.0304
E-mail: sales@qualitest-inc.com
Address: 70 East Beaver Creek Rd., #9, Richmond Hill,
Ontario L4B 3B2, Canada.

Qualitest Latin America (Mexico and LATAM Region)

E-mail: ventas@qualitest-inc.com

Qualitest KSA (Regional Office)

Tel: +966 11 500 6659
Address: Level 7, 3.09, District 3, King Abdullah
Financial District, Riyadh, Saudi Arabia

Qualitest Singapore (ASIA PACIFIC Regional Office)

Tel: +65 6393 5480 | E-mail: singapore@qualitest-inc.com
Address: 50 Raffles Place, Singapore Land Tower,
Level 46, Singapore, 048623.

Qualitest Indonesia (Representative Office)

Tel: +62 21 2985 9522 | Fax: +62 21 2985 9889
E-mail: indonesia@qualitest-inc.com
Address: One Pacific Place Level 11, Jl. Jend. Sudirman,
Kav. 52-53, SCBD Area, Jakarta 12190, Indonesia.

Qualitest FZE (Regional GCC/ME Office)

Tel: +971 4 8819252 | Fax: +971 4 8819262
Email: gcc@qualitest-inc.com
Address: Jafza One, BB 1610, Jebel Ali Free Zone,
PO Box 261440, Dubai, UAE.

Qualitest India

E-mail: india@qualitest-inc.com
Address: 15th Floor, Dev Corpora, Pokhran Road No.1,
Eastern Express Highway, Thane, Maharashtra,
Mumbai, 400601, India

